

DIVISION: 05 00 00 – METALS
Section: 05 52 00 – Metal Railings

REPORT HOLDER:
NewTechWood America Inc.
15912 International Plaza Dr.
Houston, TX 77032
www.newtechwood.com

REPORT SUBJECT:
Allure Aluminum Railing Systems

1.0 SCOPE OF EVALUATION

1.1 This Research Report addresses compliance with the following Codes:

- 2021 and 2018 *International Building Code*® (IBC)
- 2021 and 2018 *International Residential Code*® (IRC)

NOTE: This report references the most recent version of the Codes noted. Section numbers in earlier versions of the Codes may differ.

1.2 The Allure Aluminum Railing Systems have been evaluated for the following properties (see Table 1):

- Structural Performance

1.3 The Allure Aluminum Railing Systems have been evaluated for the following uses (see Table 1):

- Under the definitions of the referenced Codes, the Allure Aluminum Railing Systems are intended for use at or near the open sides of elevated walking areas of buildings and walkways as required by the Codes
- Guardrail systems recognized in this report may be used in One- and Two-Family Dwellings regulated by the IRC and all construction types regulated by the IBC in accordance with IBC sections 1607.9 and 1015

2.0 STATEMENT OF COMPLIANCE

The Allure Aluminum Railing Systems comply with the Codes listed in Section 1.1, for the properties stated in Section 1.2, and uses stated in Section 1.3, when installed as described in this report, including the Conditions of Use stated in Section 6.0.

3.0 DESCRIPTION

3.1 The Allure Aluminum Railing Systems are assemblies of extruded aluminum top and bottom rails, balusters, and structural aluminum posts, with die cast rail to post brackets, post caps and stainless steel fasteners.

3.2 The Allure Aluminum Railing Systems are provided with rail lengths of 72 inches and 96 inches measured between the inside of support posts, and installed heights of 36 inches and 42 inches measured from the top of the upper rail to the walking surface. See Table 2 for lengths and configurations.

3.3 The top rail is an extruded aluminum profile. A vinyl insert installed into underside of rail secures the balusters to the rail. See Figure 1.

3.4 The bottom rail is a square extruded aluminum profile. A vinyl insert installed into underside of rail secures the balusters to the rail. See Figure 2.

3.5 Baluster pickets are 3/4 inch square extruded aluminum profiles.

3.6 Support posts are available in 3 inch square extruded aluminum profiles. The posts are bolted to an aluminum base plate utilized to secure the rail assembly to the deck. See Figure 4.

4.0 PERFORMANCE CHARACTERISTICS

4.1 The railing system described in this report has demonstrated the capacity to resist the design loadings specified in Chapter 16 of the IBC and section R301 of the IRC when tested in accordance with ICC-ES AC 273.

5.0 INSTALLATION

5.1 General: The Allure Aluminum Railing Systems must be installed in accordance with the manufacturer's published installation instructions, the applicable Code, and this Research Report. A copy of the manufacturer's instructions must be available on the jobsite during installation.



5.2 Application: The Allure Aluminum Railing Systems must be installed in configuration identified in Table 2. See Table 3 for the fastening schedule of all the system components.

6.0 CONDITIONS OF USE

6.1 Installation must comply with this Research Report, the manufacturer's published installation instructions, and the applicable Code. In the event of a conflict, this report governs.

6.2 Only those types of fasteners and fastening methods described in this report have been evaluated for the installation of the Allure Aluminum Railing Systems. All other fastening methods are outside the scope of this report.

6.3 The aluminum post mounts are anchored to a concrete or steel surface with approved anchor bolts having a minimum nominal diameter of 3/8 inch. The type and the length of the anchor bolts is dependent upon the material and condition of the support structure and is not within the scope of this report.

6.4 Where required by the building official, engineering calculations and details shall be provided. The calculations verify that the anchorage and supporting structure complies with the Building Code for the type and condition of the supporting structure.

6.5 The Allure Aluminum Railing Systems are manufactured under a quality control program with inspections by Intertek Testing Services NA, Inc.

7.0 SUPPORTING EVIDENCE

7.1 Drawings and installation instructions submitted by the manufacturer.

7.2 Reports of testing compliance with the performance requirements of Acceptance Criteria for Handrails and Guards ICC-ES AC 273, revised June 2017.

7.3 Documentation of an Intertek approved quality control system for the manufacturing of products recognized in this report.

8.0 IDENTIFICATION

The Allure Aluminum Railing Systems are identified with the manufacturer's name (NewTechWood America Inc.), address and telephone number, the product name (Allure Aluminum Railing), when applicable "for Use in One- and Two-Family Dwellings Only.", the Intertek Mark as shown below, and the Code Compliance Research Report number (CCRR-0430).



9.0 OTHER CODES

This section is not applicable.

10.0 CODE COMPLIANCE RESEARCH REPORT USE

10.1 Approval of building products and/or materials can only be granted by a building official having legal authority in the specific jurisdiction where approval is sought.

10.2 Code Compliance Research Reports shall not be used in any manner that implies an endorsement of the product by Intertek.

10.3 Reference to the <https://bpdirectory.intertek.com> is recommended to ascertain the current version and status of this report.

This Code Compliance Research Report ("Report") is for the exclusive use of Intertek's Client and is provided pursuant to the agreement between Intertek and its Client. Intertek's responsibility and liability are limited to the terms and conditions of the agreement. Intertek assumes no liability to any party, other than to the Client in accordance with the agreement, for any loss, expense or damage occasioned by the use of this Report. Only the Client is authorized to permit copying or distribution of this Report and then only in its entirety, and the Client shall not use the Report in a misleading manner. Client further agrees and understands that reliance upon the Report is limited to the representations made therein. The Report is not an endorsement or recommendation for use of the subject and/or product described herein. This Report is not the Intertek Listing Report covering the subject product and utilized for Intertek Certification and this Report does not represent authorization for the use of any Intertek certification marks. Any use of the Intertek name or one of its marks for the sale or advertisement of the tested material, product or service must first be approved in writing by Intertek.





TABLE 1 – PROPERTIES EVALUATED

PROPERTY	2018 IBC SECTION	2021 IBC SECTION	2021, 2018 IRC SECTION
Structural Performance	1607.8.1	1607.9.1	Table R301.5

TABLE 2 – CODE OCCUPANCY CLASSIFICATION - ALLURE ALUMINUM RAILING

RAILING SYSTEM DIMENSIONS (HEIGHT * WIDTH)	RAIL TYPE	BALUSTER	POST	CODE CLASSIFICATION
42"x6'	Level	3/4 in. Square Picket	3 in. Square	IBC - All Use Group
42"x8'	Level	3/4 in. Square Picket	3 in. Square	IRC One- and Two-Family Dwellings
36"x8'	Level			
36"x6'	Level			

TABLE 3 – FASTENER SCHEDULE

CONNECTION	FASTENER
Top Rail to Bracket Post	Three #10x1", Self-drill, 304 stainless steel screws
Bottom Rail Bracket to Post	Two #10x1", Self-drill, 304 stainless steel screws
Top Rail Bracket to Rail	Two #8x3/4", Self-drill, 304 stainless steel screws
Bottom Rail Bracket to Rail	Two #8x3/4", Self-drill, 304 stainless steel screws

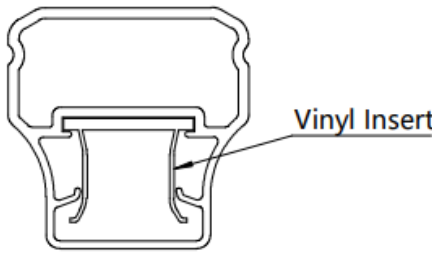

Figure 1 – Top Rail

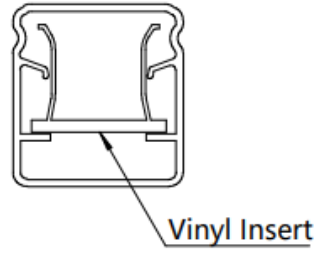

Figure 2 – Bottom Rail

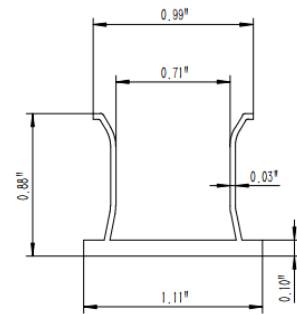

Figure 3 – Vinyl Rail Insert

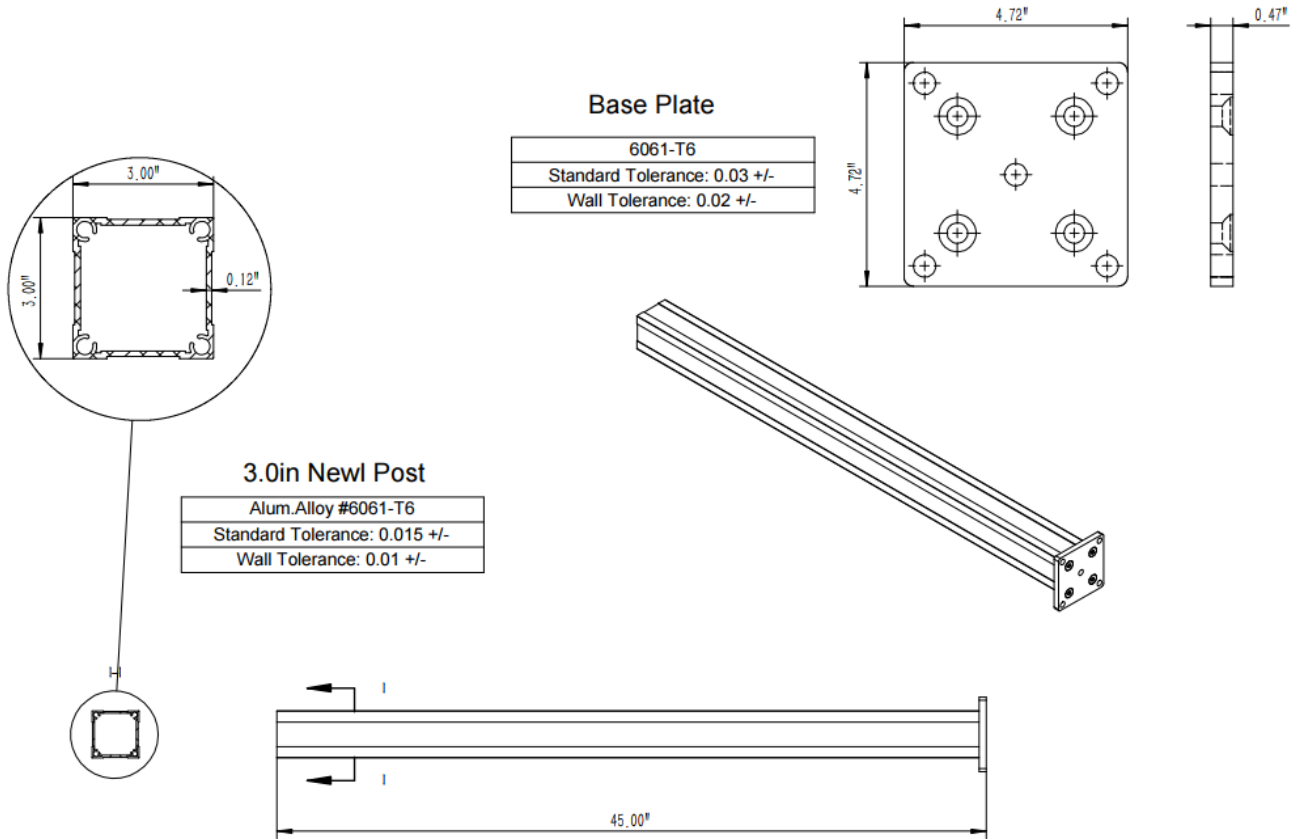

Figure 4 – Post

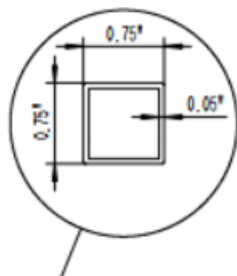

Figure 5 – 3/4 in. Picket

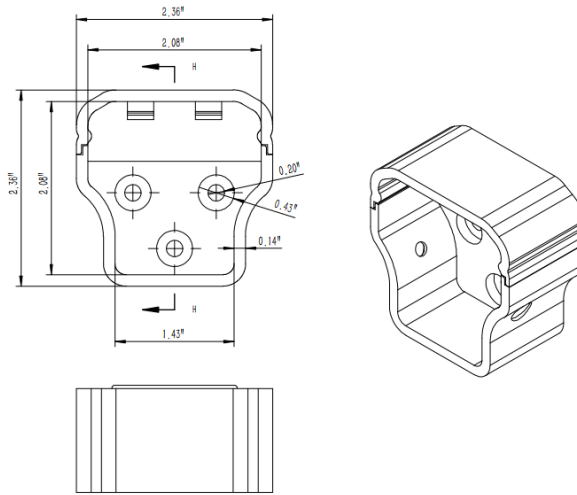

Figure 6 – Top Rail Bracket

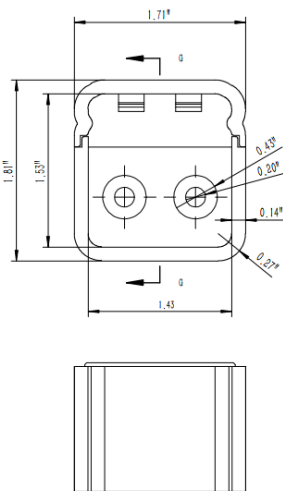

Figure 7 – Bottom Rail Bracket

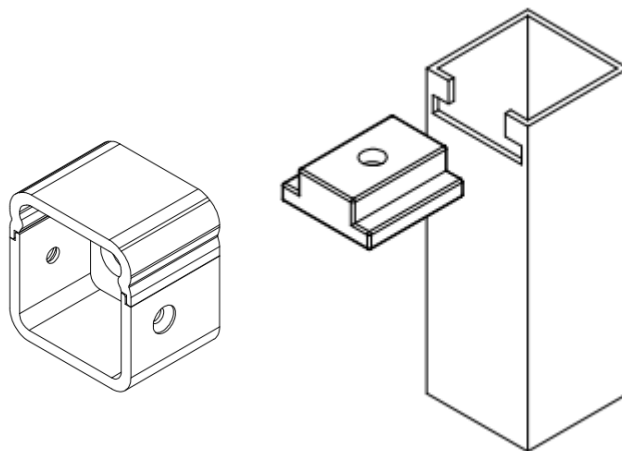

Figure 8 – Bottom Rail Support

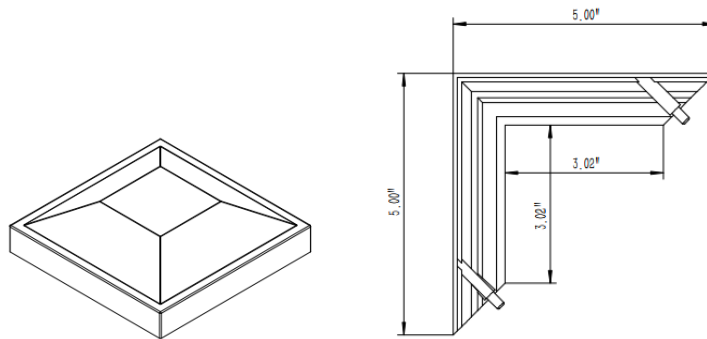

Figure 9 – Post Cap and Trim